

# SANTASALO® YANKEE CYLINDER DRIVE UNIT

For reliable and efficient tissue making with life-cycle support

Developed for tissue machine Yankee cylinder drive units, this new Santasalo gear series is based on a completely new technological solution to meet the requirements of today's high-speed tissue machines. The design of this series places special emphasis on its cost-effective and maintenance-friendly structure in order to reduce the life-cycle costs of Yankee cylinder drive units.

## NEW GENERATION DESIGN - PRE-LOAD ARRANGEMENT OF THE MAIN BEARING

The new Yankee cylinder drive series features a unique pre-load arrangement of the main bearing to optimize load distribution. This completely new design solution stabilizes the running of the Yankee cylinder drive unit and consequently extends bearing lifetime. Additionally, the pre-load arrangement of the main bearings is adjustable; very cost effective in situations where a unit is used as a spare reducer for an opposite-handed tissue machine.

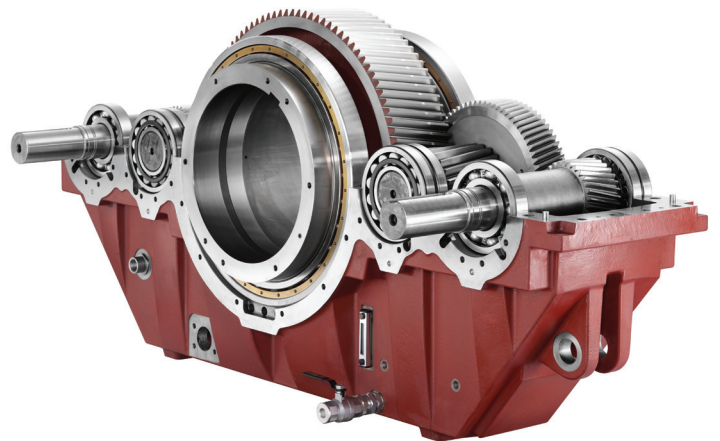

## OPERATION AND SERVICE FRIENDLY

Running with two main motors, this new series is available in three different sizes, all featuring maintenance-free labyrinth seals. The hollow shaft inside diameter can be up to 540 mm.

The forces caused by the rotary steam joint are taken into account in both possible running directions of the Yankee cylinder drive. The new symmetrical housing is modern and service-friendly, as well as easy to fit with different auxiliaries and instrumentation according to customer needs. The new Yankee cylinder drive unit can be equipped with Sunday drive in three alternative mounting arrangements.

## ADVANTAGES

- Optimal solution for production-optimized tissue machines
- Turn-key delivery including all required accessories
- Cost-effective and maintenance-friendly structure
- Low life-cycle costs due to easy maintenance



moventas

## TECHNICAL FEATURES

- **Type: Santasalo 2D2PHT Yankee cylinder drive unit series**
- **Available in three different sizes: 100, 110, 120**
  - Power range up to 2 x 2,500 kW
  - Hollow shaft bore range 280 ... 540 mm in diameter
- **Two motor driven shaft mounted units**
- **Light and rigid structure**
- **New symmetrical housing**
  - All shafts at the same joint plane for easy maintenance
  - Modern design utilizing 3D layout planning and Finite Element Method (FEM) analysis
  - Easy to fit with different auxiliaries and instrumentation according to customer needs, e.g. measurement of axial and radial vibration, and temperature
- **Can be equipped with Sunday drive**
  - Available in three alternative mounting arrangements
- **Maintenance-free labyrinth seals**
- **The hollow shaft inside diameter can be up to 540 mm**
- **Able to handle axial forces from the steam joint up to 42 kN.**

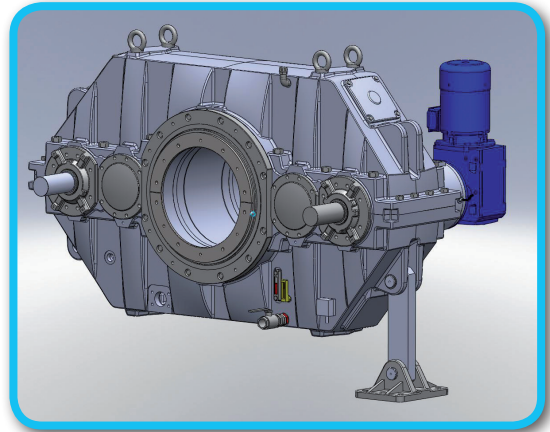

## BUILT WITH EXPERIENCE

With more than five decades of experience in supplying Yankee and TAD cylinder drives to leading tissue machine manufacturers worldwide, we have built a unique understanding and application-related competence in tissue machine dryer section drives. Yankee cylinder drive units and other equipment for tissue machine drives are delivered from Moventas Santasalo's factories in Finland and China.

The Santasalo Yankee cylinder drive units are available on a turn-key basis for new installations, rebuilds and modernizations of tissue machine dryer sections. The delivery includes everything from 3D layout planning, engineering and manufacturing complete with accessories, to start up and customer training augmented by our comprehensive range of life-cycle services.

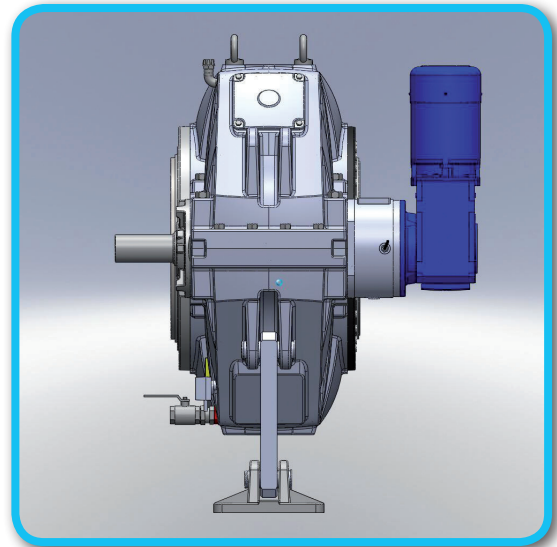

Moventas Santasalo is the original equipment manufacturer for:

**METSO DRIVES | SANTASALO | VALMET | SAUERWALD | ASEA | WÄRTSILÄ | RAUMA-REPOLA**

More information at [www.moventas.com](http://www.moventas.com)

**moventas**